

Hand Engineering's Ripper Bucket for Excavators up to 7 tonne



HIGH QUALITY. DURABLE.

The Ripper Bucket can be used in hard or rocky ground conditions.

Ripping the ground before hand will reduce the wear and tear on your machine and other digging buckets.

FEATURES

- > Replaceable Tooth System
- > Constructed of high grade weldox material for strength and durability.

SPECIFICATIONS

Available for any make or model of micro and mini excavator up to 7 tonnes operating weight.

Hand Engineering Ltd.,
Drumone, Oldcastle,
Co. Meath, Ireland
Tel: 00 353 (0)44 9666504
email: handeng@eircom.net
<http://www.handengineering.com>

HandEngineering
Manufacturing&Development

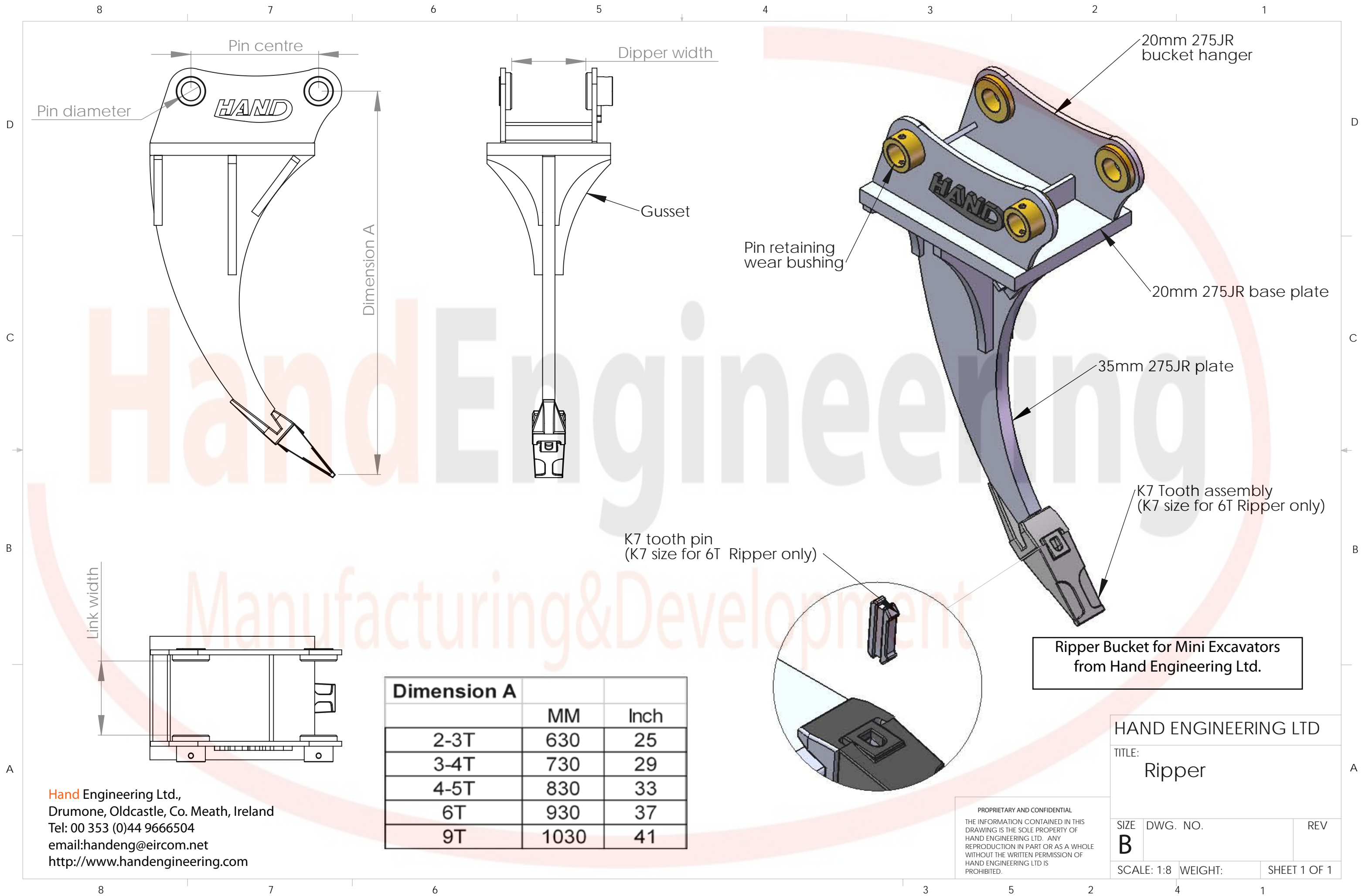

Hand Engineering Ltd.,
 Drumone, Oldcastle, Co. Meath, Ireland
 Tel: 00 353 (0)44 9666504
 email:handeng@eircom.net
 http://www.handengineering.com

Dimension A		
	MM	Inch
2-3T	630	25
3-4T	730	29
4-5T	830	33
6T	930	37
9T	1030	41

Ripper Bucket for Mini Excavators
 from Hand Engineering Ltd.

HAND ENGINEERING LTD		
TITLE: Ripper		
SIZE B	DWG. NO.	REV
SCALE: 1:8	WEIGHT:	SHEET 1 OF 1

PROPRIETARY AND CONFIDENTIAL
 THE INFORMATION CONTAINED IN THIS
 DRAWING IS THE SOLE PROPERTY OF
 HAND ENGINEERING LTD. ANY
 REPRODUCTION IN PART OR AS A WHOLE
 WITHOUT THE WRITTEN PERMISSION OF
 HAND ENGINEERING LTD IS
 PROHIBITED.